

# Standard Spezialprofile für Hubstapler Standard Special Profiles for Lift Trucks

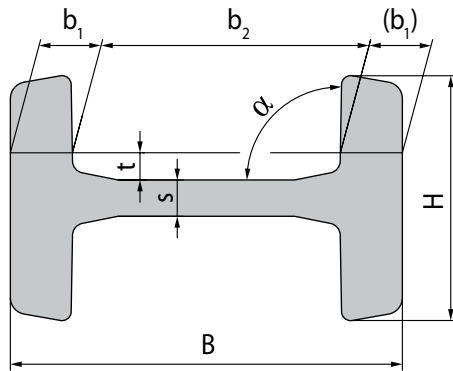

Hubschienen  
H-Standard 1–5  
warmgewalzt \*)

*Mast Profiles  
U-Standard 1–5  
hot rolled \*)*

Nr.	Abmessungen · Dimensions												Gewicht kg/m	W <sub>x</sub> ≈ cm <sup>3</sup>	W <sub>y</sub> ≈ cm <sup>3</sup>
	B	b <sub>1</sub>	Tol.	b <sub>2</sub>	Tol.	H	Tol.	s	Tol.	t	α	Tol.			
3018 Standard 1	98,0	14,0	±0,5	70,0	+1,0	65,0	±1,0	9,0	±0,5	7,0	91°	+1°	19,4	70	18
3019 Standard 2	113,9	18,0	±0,5	77,9	+1,0	66,0	±1,0	11,0	±0,5	9,0	91°	+1°	25,3	105	23
3020 Standard 3	129,6	20,5	±0,5	88,6	+1,0	81,0	±1,25	12,0	±0,5	9,0	91°	+1°	34,1	160	40
3100 Standard 4	152,4	22,0	±0,5	108,4	±0,5	83,0	±1,0	14,0	±0,5	9,0	91°	+1°	40,5	219	45
3353 Standard 5	175,0	25,6	±0,5	123,8	±0,5	90,0	±1,3	15,0	±0,5	12,5	91°	+1°	51,4	322	65
2911 US-Standard	101,5	12,5	±0,8	76,5	+0,8	60,3	±1,6	9,5	±0,5	9,0	91°	+1°	17,8	67	15
3440 US-Standard	139,7	18,9	±0,8	101,9	+0,8	69,9	+1,6	12,7	±0,5	9,0	91°	+1°	30,9	154	30
2912 US-Standard	140,2	18,96	±0,8	102,28	-0,8	69,9	+1,6	12,7	±0,5	8,0	91°	+1°	31,2	157	31
3468 US-Standard	175,0	23,5	±0,8	128,0	-1,0	76,2	—	12,7	±0,5	11,5	92°	+15°/-45°	41,9	267	45

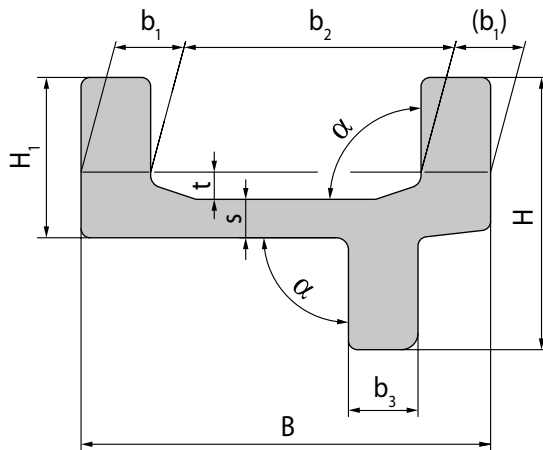

Hubschienen  
U-Standard mit Steg  
warmgewalzt \*)

*Mast Profiles  
U-Standard with flange  
hot rolled \*)*

Nr.	Abmessungen · Dimensions												Gewicht kg/m	W <sub>x</sub> ≈ cm <sup>3</sup>	W <sub>y</sub> ≈ cm <sup>3</sup>		
	B	b <sub>1</sub> /b <sub>3</sub>	Tol.	b <sub>2</sub>	Tol.	H	Tol.	H <sub>1</sub>	Tol.	s	Tol.	t				α	Tol.
3360	103,2	16,2	±0,5	70,8	±0,5	63,0	±1,0	38,0	±0,8	7,7	±0,5	8,5	90°	±1°	17,3	50	14
3351	121,3	21,3	±0,5	78,7	±0,5	68,0	±1,0	41,0	±0,8	10,8	±0,5	8,0	90°	±1°	25,2	80	21
3384	135,4	23,0	±0,5	89,4	±0,5	90,0	±1,3	53,0	±1,0	12,7	±0,5	9,0	90°	±1°	34,9	127	40
3352	157,2	24,4	±0,5	108,4	±0,5	105,0	±1,3	61,2	±1,0	14,0	±0,5	9,0	90°	±1°	43,9	190	58

\*) Auf Anfrage sind alle aufgeführten Profile auch als kaltgezogene oder gefräste SE-IMI®-Variante erhältlich.

\*) All above-mentioned profiles are also available as cold drawn or milled SE-IMI®-version on request.